

00-E0-05+7H

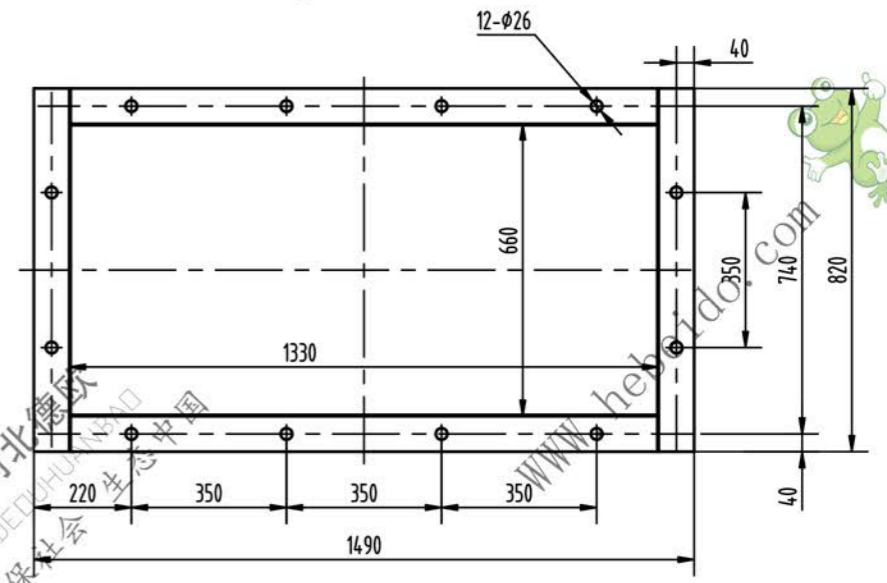

地基基础

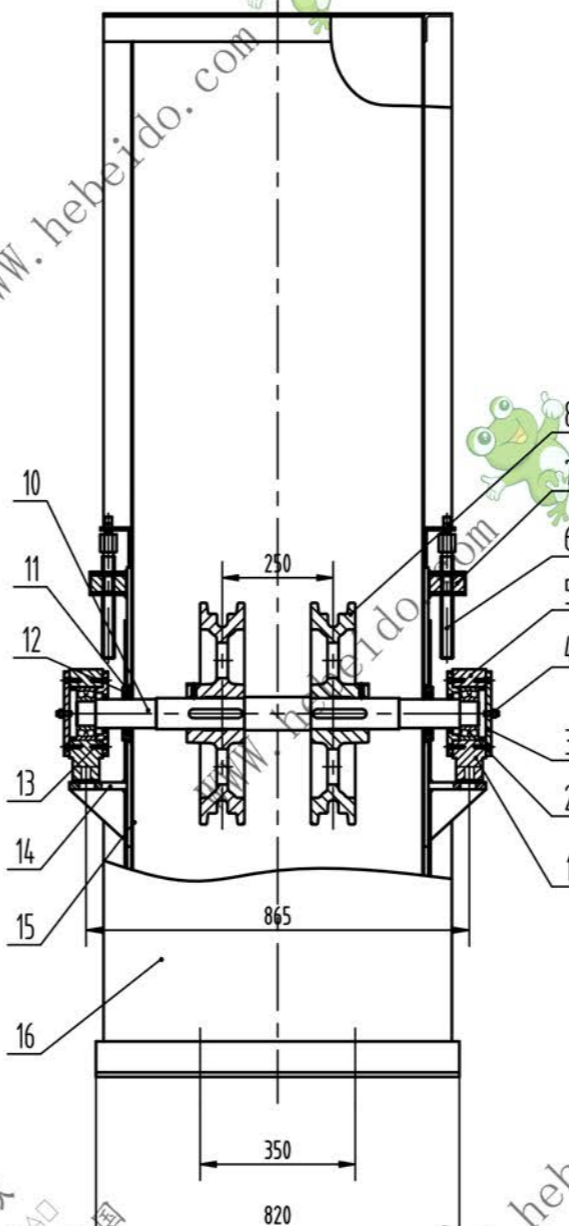
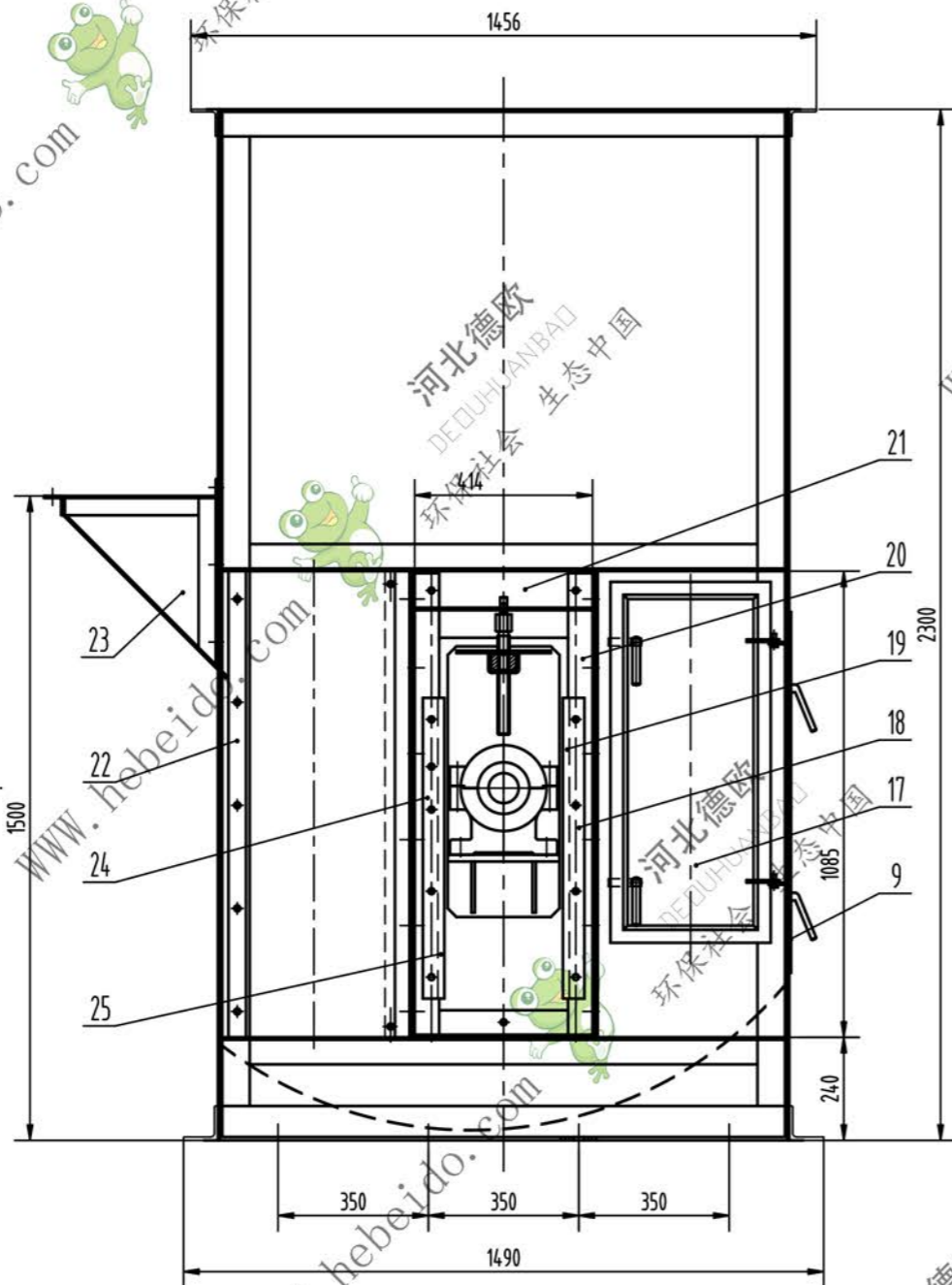
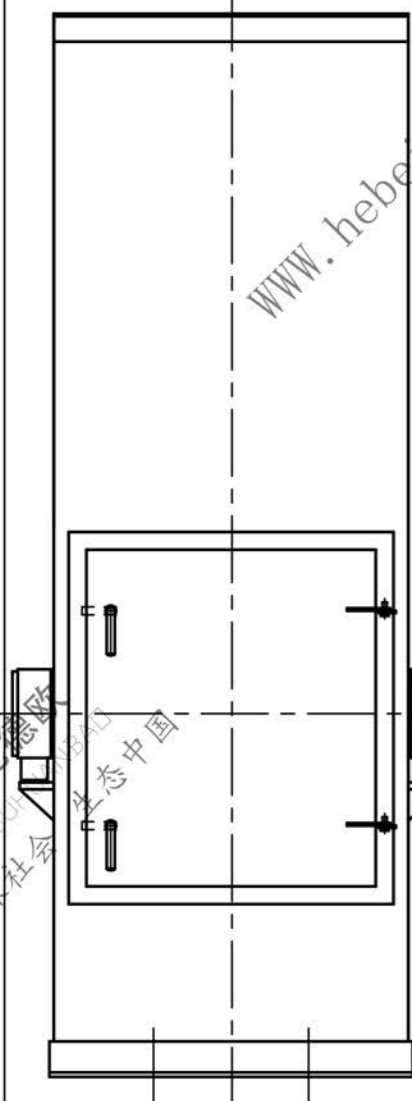
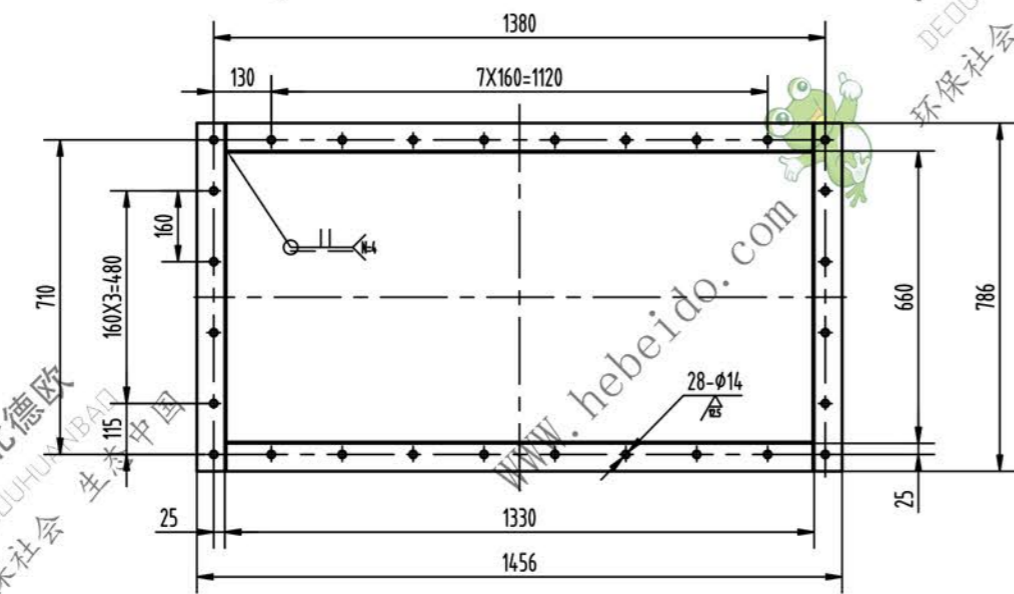

25	HL450-03-22	左导板	2	A3 δ=5				
24	HL450-03-21	左镜板	2	A3 δ=4				
23	HL450-03-20	进料口	1	A3焊合件				
22	HL450-03-19	侧板	2	A3焊合件				
21	HL450-03-18	压紧角钢	2	A3焊合件				
20	HL450-03-17	导架	2	A3焊合件				
19	HL450-03-16	右导板	2	A3 δ=5				
18	HL450-03-15	右镜板	2	A3 δ=4				
17	HL450-03-14-00	观察门	2	A3组合件				
16	HL450-03-13-00	下部机壳	1	A3焊合件				
15	HL450-03-12	护板	2	A3 δ=3				
14	HL450-03-11	滑动支板	2	A3焊合件				
13	HL450-03-10	尾轴承座通盖	2	HT150				
12	HG4-692-67	骨架式橡胶油封	2	65X95X12				
11	HL450-03-09	尾轴油封盖	2	A3				
10	HL450-03-08	尾轴	1	φ55				
9	HL450-03-07	侧观察门	1	A3 δ=3				
8	HL450-03-06	尾部轮缘	2	ZG310-570				
7	HL450-03-05	螺母	2	A3				
6	HL450-03-04	拉紧螺钉	2	A3				
5	HL450-03-03	尾轴承盖	2	HT200				
4	GB1152-89	直通式压注油杯	2	M10X1				
3	HL450-03-02	尾轴承座闷盖	2	HT150				
2	GB286-64	双列向心滚子轴承3611	2	55X120X43				
1	HL450-03-01	尾部轴承座	2	HT200				

序号	代号	名称	数量	材料	单件重量	总计重量	备注
					HL450-03-00		尾部组装
标记	外委	分区	更改文件号	签名	年月日		
设计	李连通		标准化			阶段标记	重量 比例
审核	秦海波						1件/台 1:12
工艺	刘飞		批准			共张	第张

